

S E R V I C E N O T E

SUPERSEDES:

NONE

HP MODEL 8654A SIGNAL GENERATOR
Serial Prefix 1530A and Below
MICROPHONICS REDUCTION KIT

The susceptibility of the 8654A to microphonics can be substantially reduced by installation of HP 08654-60047 Microphonics Reduction Kit. This applies to instruments with serial prefix 1530A and below. With the kit installed the microphonics susceptibility will be similar to the 8654A with serial prefix above 1530A or to the 8654B.

The kit suspends the RF Assembly (A1) on rubber damp pads and acoustically insulates the RF assembly cover with foam. Installation of the kit consists of replacing the RF assembly cover and suspending the RF assembly by two bars which hold the damp pads. The modification requires a simple drilling operation but no electrical changes. Commonly available tools are used. A rubber adhesive such as Dow Corning 732RTV and a thread adhesive such as Loctite are required.

The contents of the kit are listed in Table 1.

Preliminary

1. Peel backing from foam damp pads (HP 1530-1766 and 1530-1767) and apply to back and sides of new RF assembly cover.
2. Peel backing from caution label (HP 7120-4628) and stick label to top support bar (HP 08654-20069) as in Figure 1.
3. Apply a drop of Loctite to threads of two standoffs (HP 08654-20080) and screw into top support bar as in Figure 1. Note that they go on the side opposite the two counter-bored holes. Tighten standoffs slightly with a wrench but do not overtighten. Let dry overnight.
4. Degrease four setscrews (HP 3030-0564). Apply a drop of Loctite to bottom threads. Screw into RF assembly cover until 5/8 inch (15 mm) or slightly less protrudes on outside. Let dry overnight.

JH/GZ/WN

12/75-04

**HEWLETT
PACKARD**

For more information, call your local HP Sales Office or East (201) 265-5000 • Midwest (312) 677-0400 • South (404) 436-6181 • West (213) 877-1281. Or, write: Hewlett-Packard, 1501 Page Mill Road, Palo Alto, California 94304. In Europe, Post Offices Box 85, CH-1217 Meyrin 2, Geneva, Switzerland. In Japan, Yokogawa-Hewlett-Packard, 1-59-1, Yoyogi, Shibuya-Ku, Tokyo, 151.

5. Cement four damp pads (HP 4320-0281) into counter-bored holes in RF assembly cover. Use Dow Corning 732RTV or equivalent. Let dry overnight.
6. After Loctite has set on setscrews, clip flex tubing (HP 0890-0573) into four 1/4-inch (6 mm) lengths and slip over tips of setscrews. This is easily done by slipping tubing over tip of a pair of needle-nose pliers and, while prying jaws apart, slipping tubing over setscrews.

NOTE

The setscrews limit the motion of the RF assembly during a violent shock.

Disassembly

1. Remove instrument top, bottom, and side covers.
2. Remove two L-brackets from top of sideframes.
3. Remove TUNE and RANGE knobs.
4. Disconnect two semi-rigid coax cables (W4 and W2) that lead to RF assembly. See Figure 1.
5. Unplug interconnect plug (P1) on sideframe.
6. Remove cable clamp that secures wiring harness to sideframe (near P1). Clip cable ties around right support.
7. Remove four supports that secure RF assembly to sideframes.
8. Carefully remove RF assembly from instrument.
9. Remove RF assembly cover.

Modification

1. Screw large threaded plug (or plugs) from old RF assembly cover into new cover. Some older covers have only one plug; use the extra plug supplied in the kit (HP 08654-20070).
2. Install RFI braid from old RF assembly cover into new cover.
3. Install new RF assembly cover onto RF assembly. Secure the four screws very tightly.
4. Remove interconnect connector (J1) from sideframe. Bend tab of angle bracket nearest front until it breaks off. Swivel other angle bracket away from sideframe.
5. Install connector onto new connector support bracket (HP 08654-00049) with two 4-40 x 0.5" pan head screws and nuts supplied (HP 2200-0147 and 2260-0009).

6. Install bracket onto sideframe with two 6-32 flathead screws which formerly held on the two L-brackets.
7. Drill two 5/32-inch (0.156 inch or 4 mm) holes into attenuator support bracket as shown in Figure 3. Use a center punch to locate the two holes before drilling. The support bracket need not be removed for this operation.
8. Install handle from old top cover onto new top cover.

Reinstallation

1. Install bottom support bar (HP 08654-20071) onto bottom of sideframes with four 6-32 x 0.375" flathead screws (HP 2360-0118). See Figure 2.
2. Before installing RF assembly:
 - a. Check that semi-rigid coaxial cables W2 and W4 are firmly connected to A1A1J2 and A1A1J3.
 - b. Ensure that four large pan-head screws that secure RF assembly covers are tight.
3. Set RF assembly into instrument.
4. Install top support bar onto top of sideframes with four 6-32 x 0.375" flat-head screws. See Figure 1. All four damp pads and setscrews (with tubing) must fit into the proper support bar holes. If top support bar is difficult to fit into place, loosen upper screws in one of sideframes and try again.
5. Reconnect two RF cables (W2 and W4).
6. Plug interconnect cable P1 into J1 and secure old cable clamp. Route under top support bar.
7. Reinstall knobs.
8. To minimize the possibility of microphonics:
 - a. Check that four rubber damp pads are in place in top and bottom support bars.
 - b. Check that semi-rigid coaxial cables W2 and W4 are firmly connected at J5 and A2J1. The cables should not be touching the RF assembly casting. The cables should be wrapped together at approximately 2-inch intervals.
 - c. Check that FREQUENCY RANGE and TUNE knobs do not touch front panel as they turn through their range.
9. Reinstall covers.
10. Check frequency dial accuracy.

Table 1. 08654-60047 Microphonics Reduction Kit Parts List

Description	Qty	Part Number
Top Cover	1	08654-00037
Connector Support Bracket	1	08654-00049
Top Support Bar	1	08654-20069
Threaded Plug	1	08654-20070
Bottom Support Bar	1	08654-20071
RF Assembly Cover	1	08654-20076
Top Cover Standoff	2	08654-20080
Flex Tubing	2 in.	0890-0573
Cable Tie	6	1400-0249
Back Damp Pad	1	1530-1766
Cover Damp Pad	1	1530-1767
4-40 x 0.5" Pan Head Screw	2	2200-0147
4-40, 0.25" Hex Nut with Lockwasher	2	2260-0009
6-32 x 0.375" Flathead Screw with Lockwasher	8	2360-0118
10-32 x 0.875" Setscrew	4	3030-0564
Silicon Rubber Damp Pad	4	4320-0281
Caution Label	1	7120-4628
Service Note	1	P-08654-60047

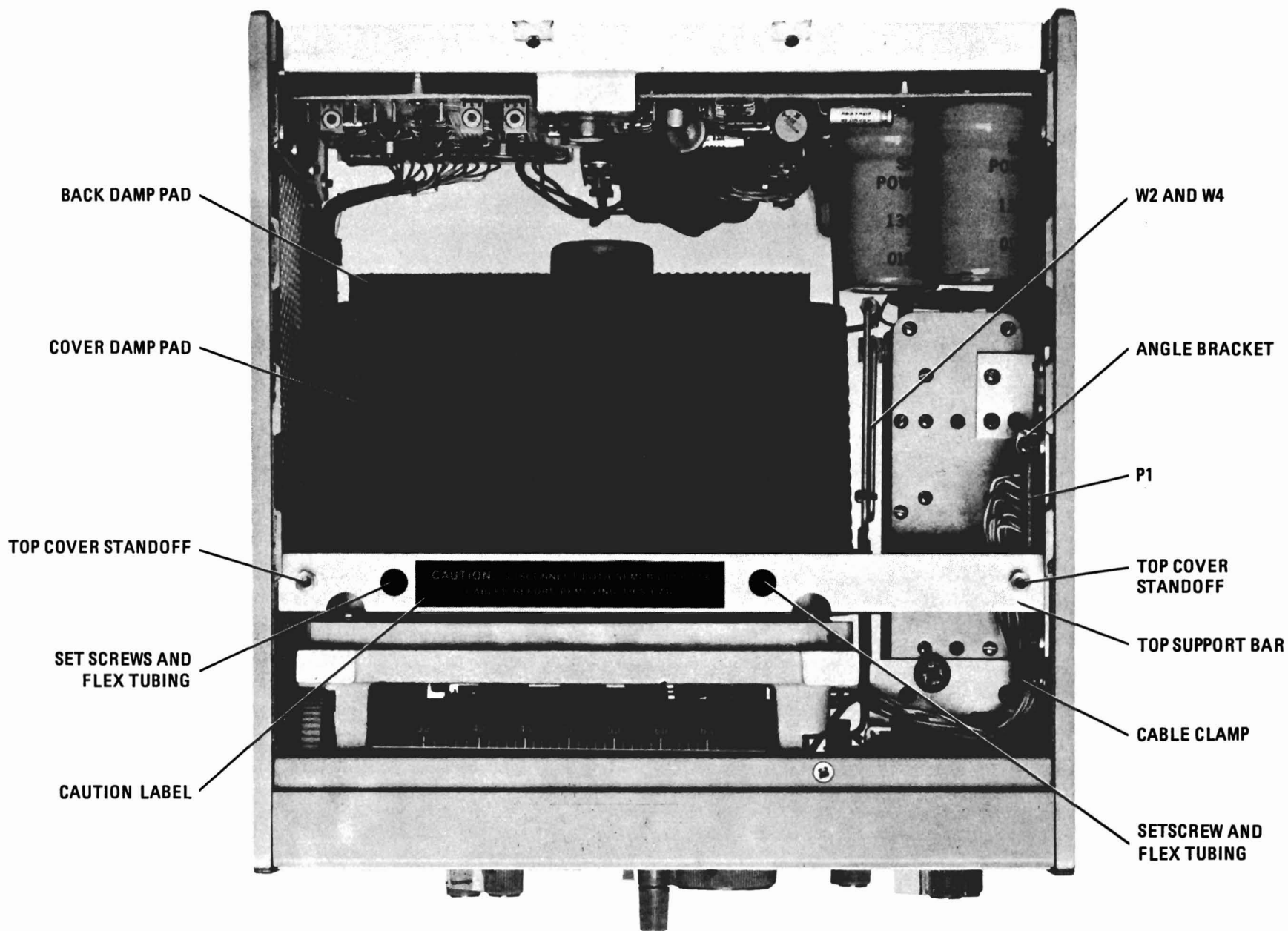

Figure 1. Top View with Kit Installed

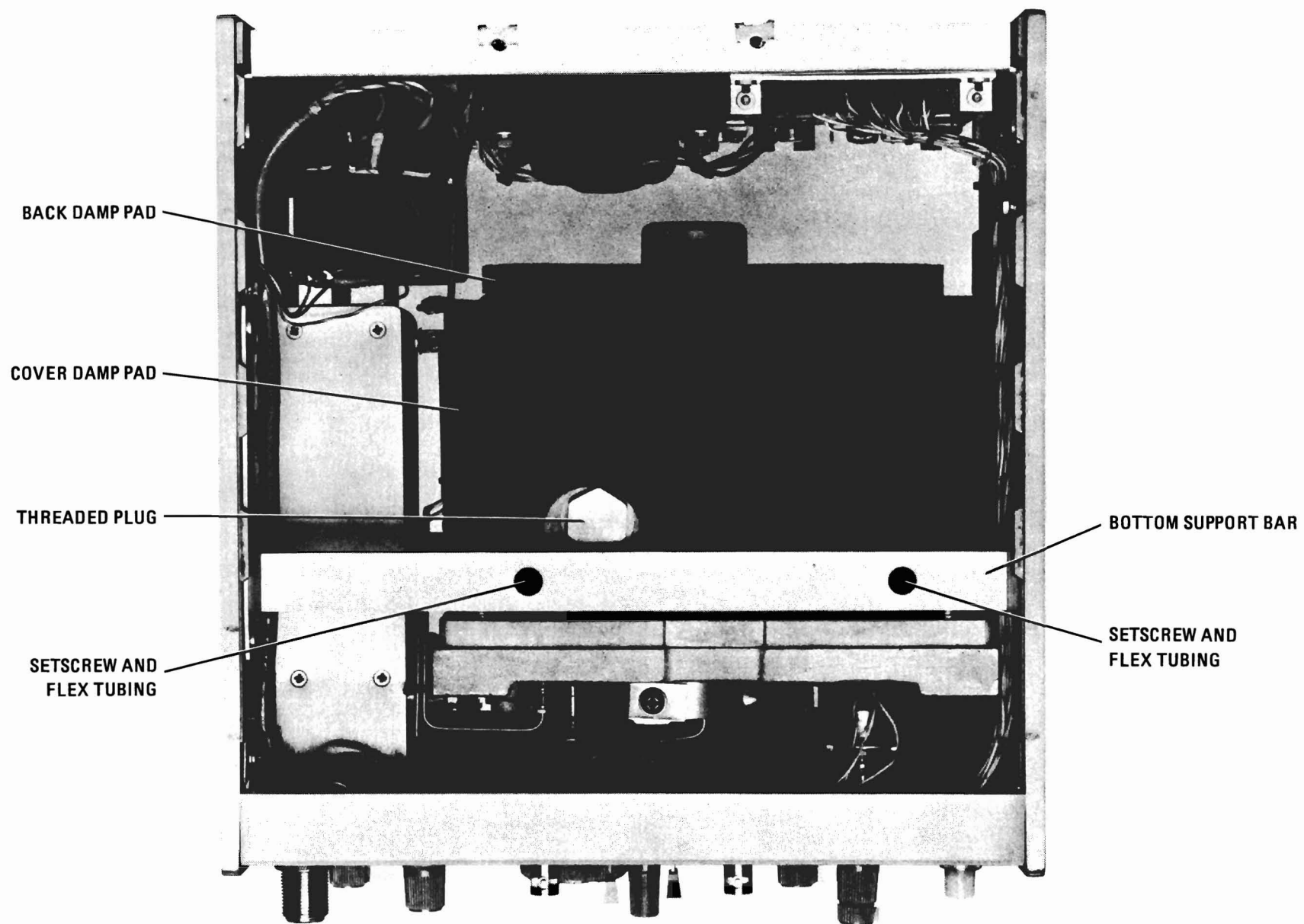

Figure 2. Bottom View with Kit Installed

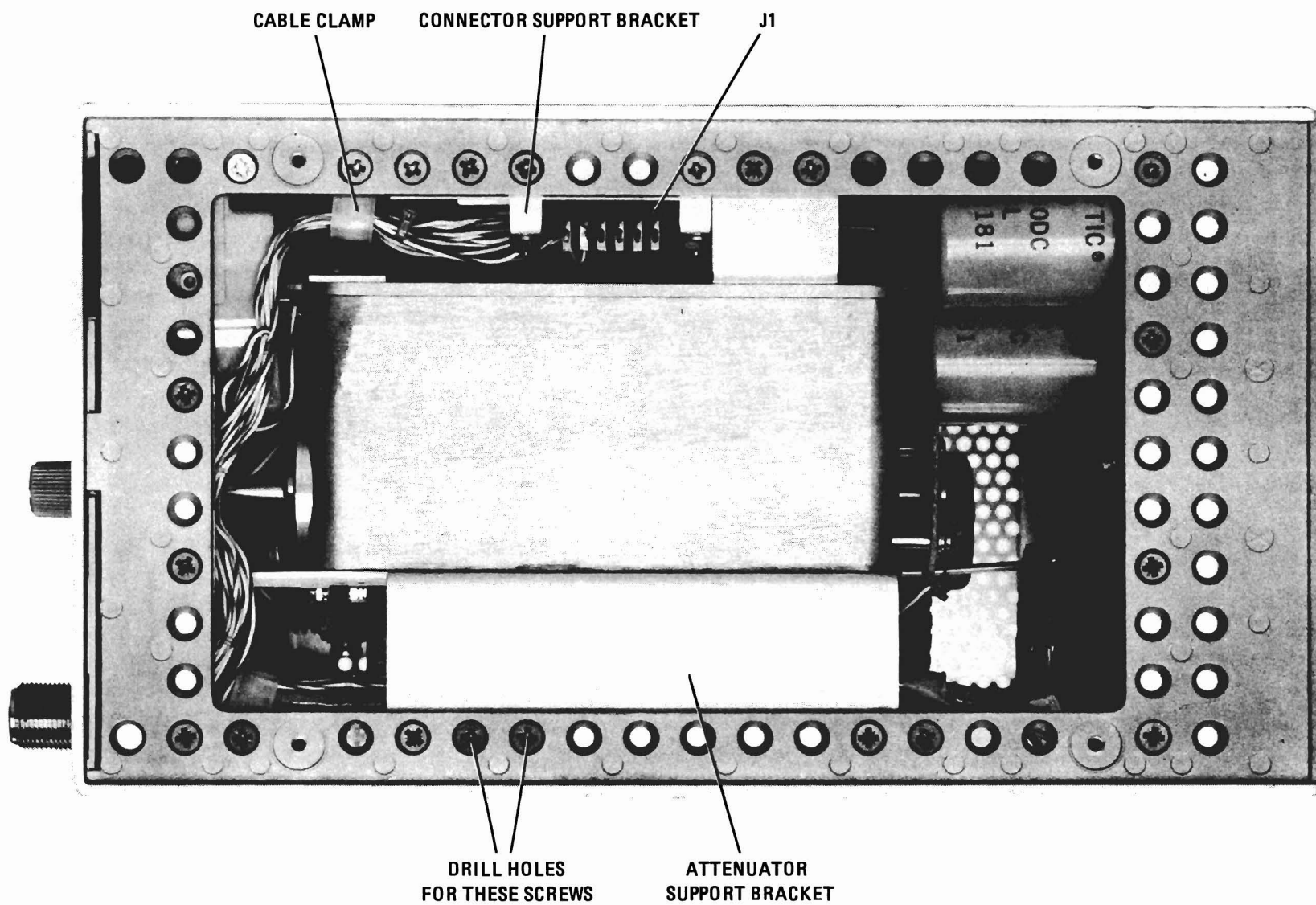

Figure 3. Right Side View with Kit Installed